

博星 模架



UV

UV



浙江博星（模架）模料有限公司
ZHEJIANG BOXING (MOULD) DIE MATERIAL CO.,LTD

模架业务 电话(Tel) : 0576-84036000
Mould 传真(Fax) : 0576-84296988

模料销售 电话(Tel) : 0576-84190933 84278000
Die Material 传真(Fax) : 0576-84051599

地址：浙江省台州市黄岩区新城路235号
Add: No.235,Xincheng Road,Huangyan District, Taizhou ,Zhejiang

 zjbxml_tz@163.com

浙江博星(模架)模料有限公司
ZHEJIANG BOXING (MOULD) DIE MATERIAL CO.,LTD

**BOXING SPREADS
THROUGHOUT
CHINA. MOVES
FORWARD
TO THE WORLD**

博及中华 星绕环球



打造国际一流品牌的**模架模料**企业

COMPANY INTRODUCTION 企业简介

浙江博星模料有限公司创建于2012年，模架部成立于2015年，坐落在中国模具之都—台州黄岩，由母公司浙江黄岩威豪模钢有限公司发展而成立。公司专业制造中大型塑胶模架、压铸模架，擅长汽车模、家电模、薄壁模等复杂模架，母公司经营国内外中高端优质模具钢、机械加工、热处理等一条龙综合性服务型企业。

公司占地面积约25000平方米，员工200多人，模架年产量1亿多元，模料年销售额达3亿多元，拥有现代化办公生产环境，一流的设备，一流的技术，一流的服务。经过几十年的不懈努力，今天的博星已是台州市金属流通行业协会常务副会长兼秘书长单位，宝钢股份模具钢直供用户，沙钢台州地区模具钢总代理，2012—2016连续五年被评为“浙江省钢贸百强企业”“台州市金属行业十强企业”。

公司为迎合中高端市场的需求，投资6000万采购了百余台国内外高端五轴枪铣复合机，四轴镗铣床，中大型CNC数控加工中心，三坐标测量仪，热处理生产线等一系列设备，最大加工工件5000*2500，最大检测设备3000*2000。经过几十年的努力，现已跟国内汽车主机厂，家电主机厂都已经开展合作。

公司依托原有的材料平台，裂变拓展模架生产线，坚持“诚信、务实、合作、双赢”的经营理念，力争成为国际一流的模具企业供应商，为模具行业做出更大的贡献，期待与您最真诚的合作！

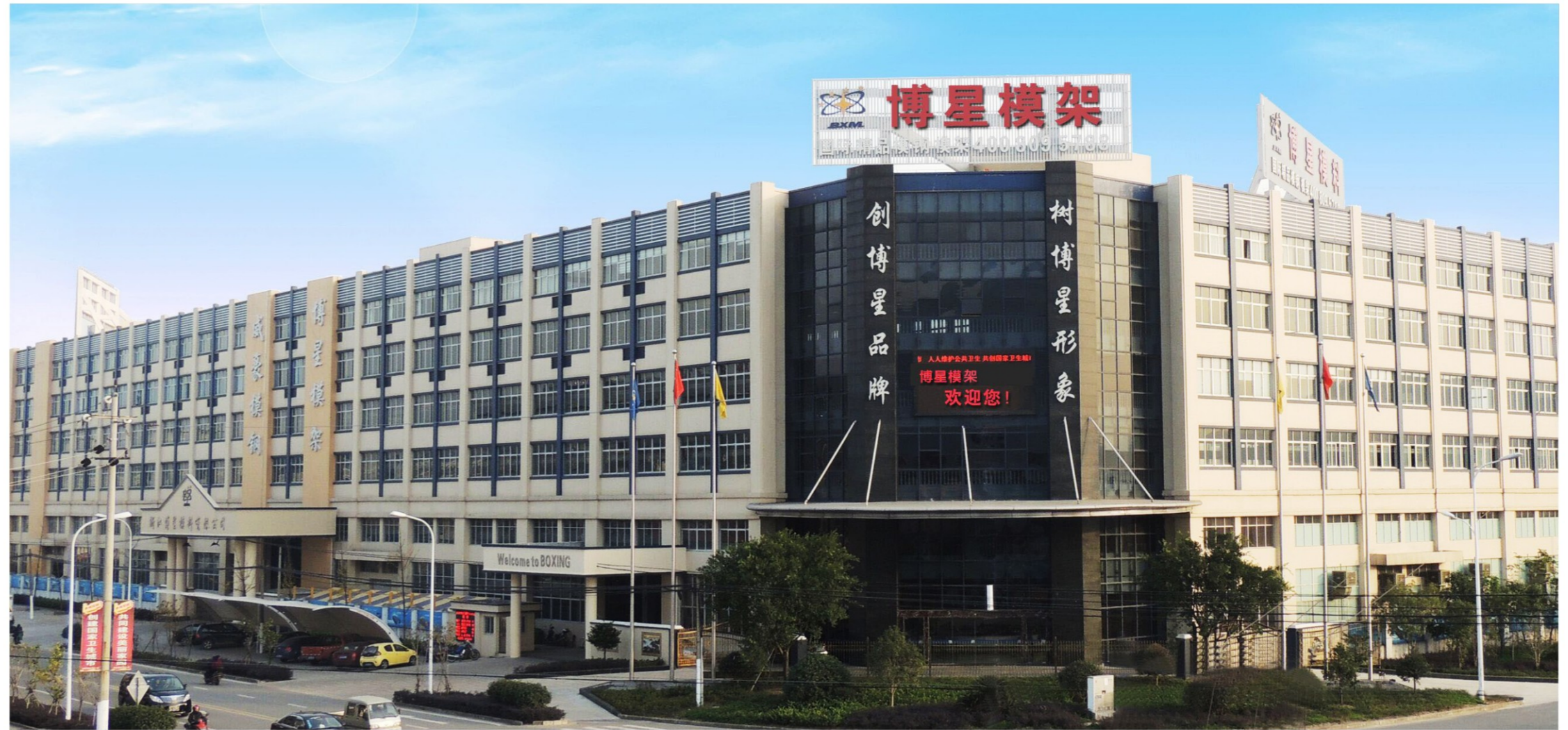

先卖服务，后卖产品
sell products after service

Zhejiang Boxing steel material CO.,LTD founded in 2012,Mould department set up in 2015, Locates in China mould city Huangyan, Developed by parent company Zhejiang Huangyan Weihao Mould steel material CO.,LTD. The company specializes in manufacturing medium large plastic mould frame, die casting mould, metal mould frame, Good at car mould, home appliance, thin wall mould and other complex mould,is a one-stop enterprise specialized in high-end and qualified mould steel marketing, precision machining operation, heat treatment etc.

Covering an area of 25000 square meters, our company has around 200 employees, Mold year sales of about 100 million, mould steel annual sales about 300 million , Our company possesses modern office environment, First-class equipment, first-class technology, first-class service. Through years of unremitting efforts of all the company members, our company becomes one of the senior vice-chairman units of Taizhou metal circulation industry, and direct supplier of Baogang Iron and Steel plant.Shagang taizhou area mold steel general agent Besides, Boxing was rated as Zhejiang TOP100 steel enterprise from2012to2016years, and won the title of Taizhou top 10 metal industrial enterprises.

To meet increased demand in the high-end market,60 million investment at home and abroad more than purchasing the best high-end five-axis milling complex machine gun, four shaft boring and milling machine, large CNC machining center, three coordinate measuring instrument, heat treatment production line and a series of equipment, 5000 * 2500 largest machining maximum detection equipment 3000 * 2000. After several decades of efforts, now with the domestic automobile main engine plant, home appliance factory has already carried out cooperation.

We rely on original materials platforms, numbers of precision mold production line, excellent professionals, and adhere to the "integrity, pragmatic, cooperation, win-win" business philosophy, to strive to become a world-class supplier for the mold industry to make greater contributions, looking forward to sincere cooperation with you!



COMPANY HONOR

企业荣誉

荣誉属于过去，
更高更远的目标还在远方，
相信自强不息的博星人
会创造一个又一个辉煌奇迹。

Honors belong to the past, and the higher and father objective is still far ahead. We are convinced that the Boxing people who are always making unremitting efforts to improve themselves will create glorious wonders one after another.

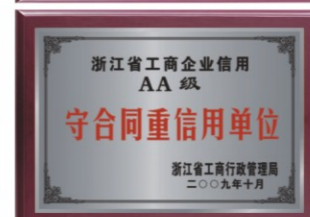

ENTERPRISE FACE 企业风采

发展中不忘稳健，稳健中谋求发展！
In developing does not forget
the steady, healthy
development!



企业联欢会
Corporate party

公司会议
Meeting



走进博星
Approaching Boxing



没有完美的个人，只有完美的团队，团队就是我，我就是团队！
No one is perfect, just only perfect team. The team is me, I am the team.

项目讨论
Talk about project



公司展会
Exhibition

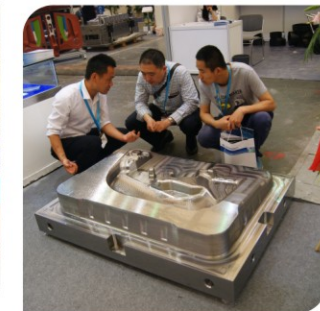

旅游合影
Some picture of our trip



演习合影
Some picture of Rehearsal



追求卓越 合作共赢 创造价值

The pursuit of excellence cooperation a win-win situation to create value



博及中华 星绕地球

创新
innovate



团结
Unite



进取
Be enterprising

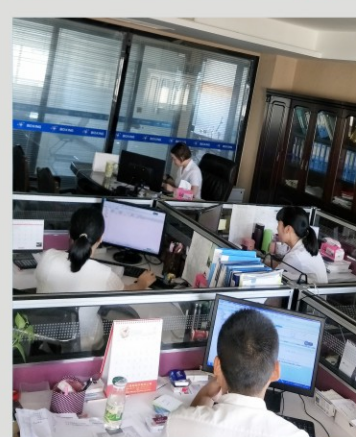

拼搏
struggle



合作
Cooperation

TECHNOLOGICAL PROCESS 工艺流程

每一道工艺，都要求精益求精！
Every process is keeping improving!



MOULD SET WORKSHOP

模架车间

工欲善其事，必先利其器

First get the sharpened, and then get the successful execution.

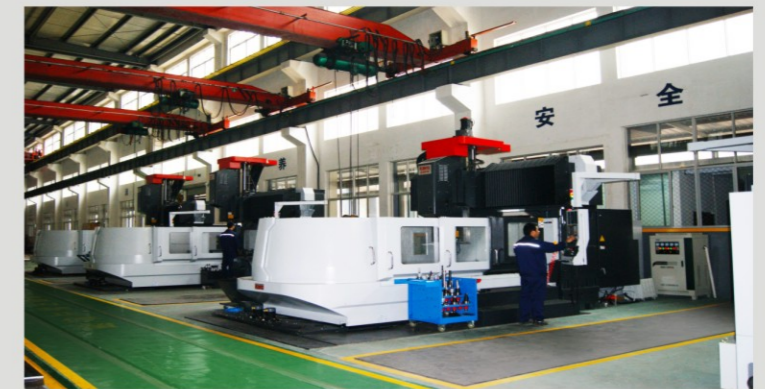

MOULD SET WORKSHOP

模架车间

五轴枪铣复合机床特别适用于有复合角度的加工工件，在铣削、钻孔（深孔）、镗孔加工以及螺纹方面有卓越表现。
Five-axis gun milling compound machine is especially suitable for machining workpiece with compound Angle. It has excellent performance in milling, drilling hole (deep hole), boring machining and thread.

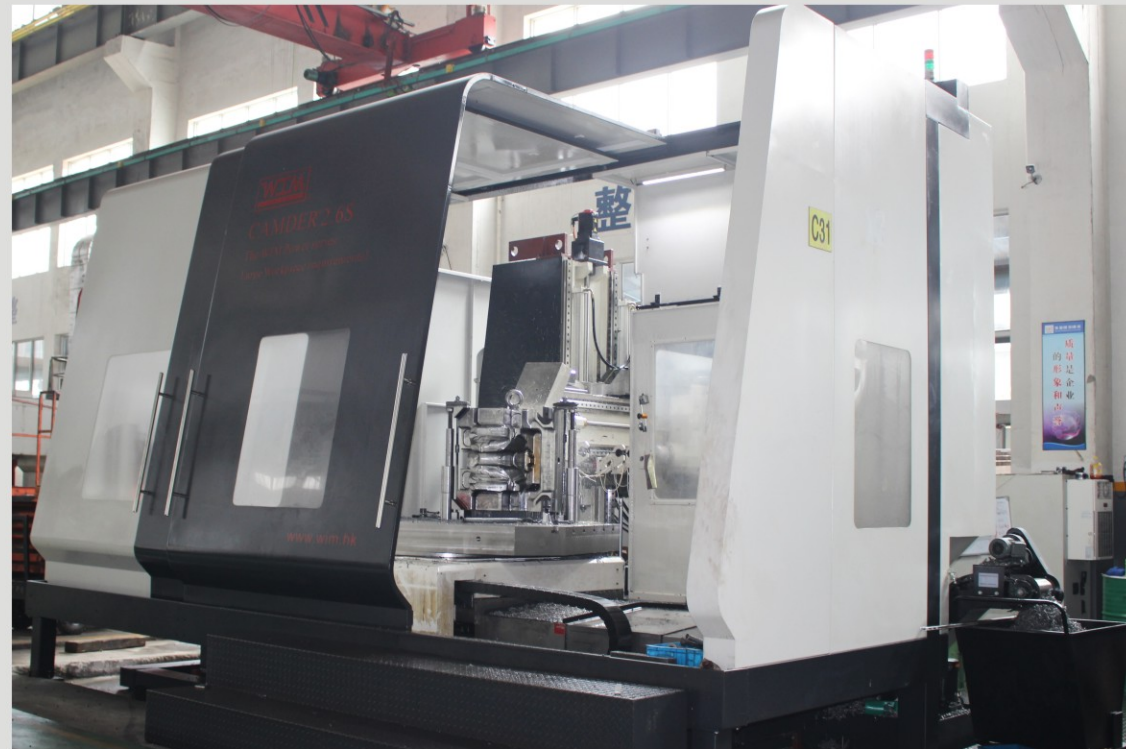

MOULD SET WORKSHOP

模架车间



大型精密磨床



四轴镗铣床



精密的产品出自精良的设计、先进的软件、精密的设备、精湛的模架，使我们生产出的产品达到精、准、零缺陷的要求，让客户充分满意。

As we process good product moulding facilities and latest software , we are able to produce a high level of products with zero error . Hence, we strongly believe our products can fully achieve our customer's requirement.

MOULD SET WORKSHOP

模架实物展示

博及中华 星绕环球
Boxing spreads throughout china.
Moves forward to the world

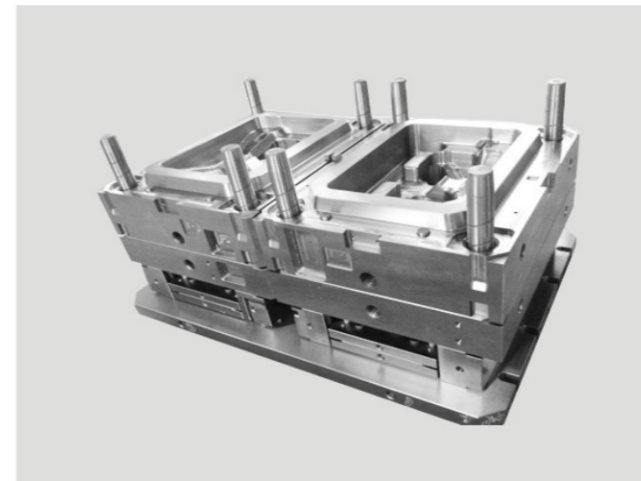
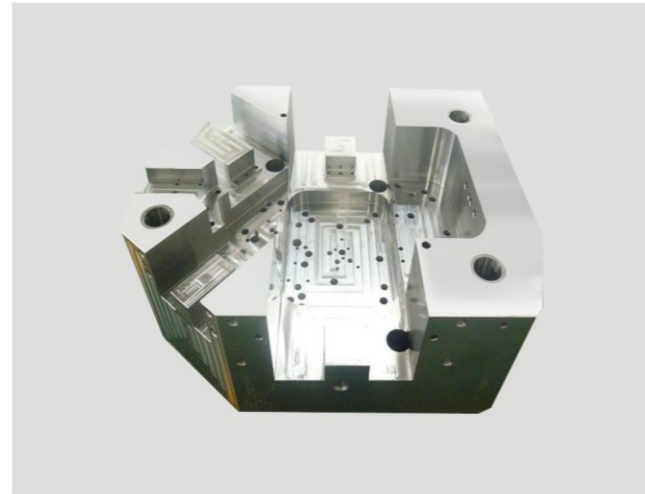
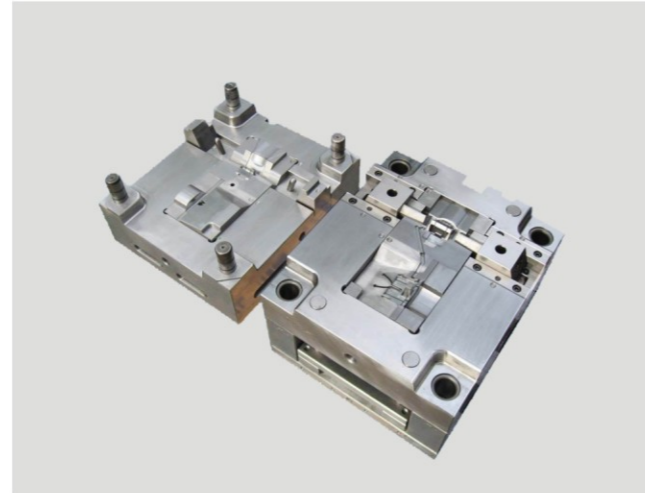
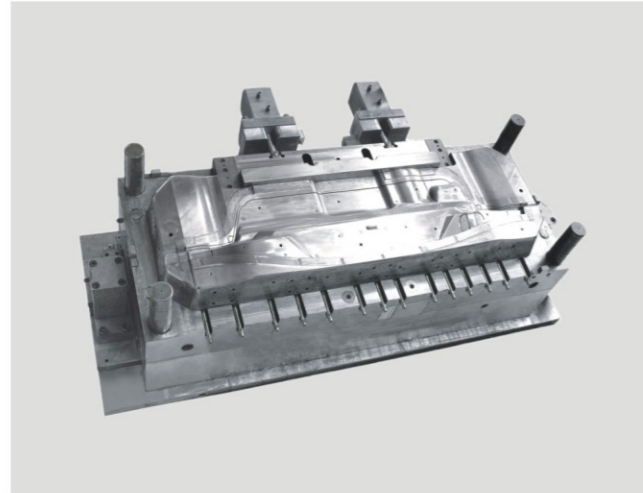
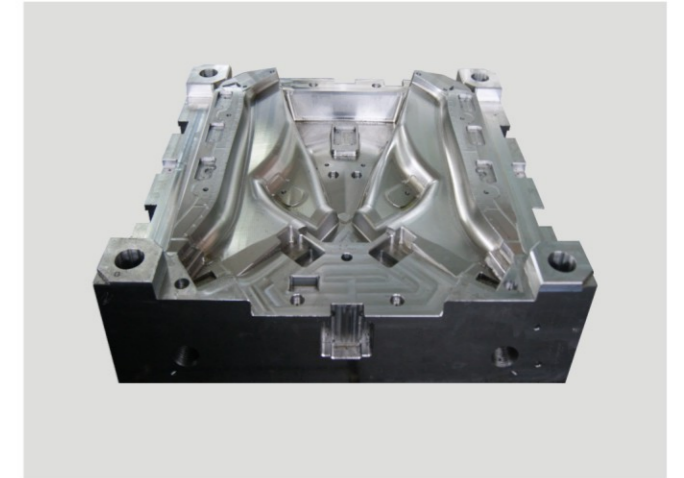
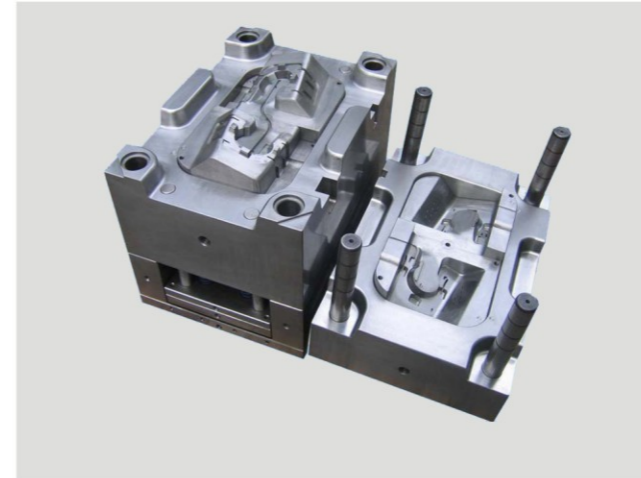

专业制造中大型塑胶模架、压铸模架、五金模架，擅长汽车保险杠、内外饰件、仪表盘、车灯、家电、薄壁等复杂模架。
Professional manufacturing medium large plastic mold, die casting mould, metal mold, good at car bumpers, interior and exterior trim, dashboards, headlights, home appliances, thin wall and other complex modes.

MOULD SET WORKSHOP

模架实物展示

高效 务实 团结 创新
Efficient Pragmatic Solidarity Innovation

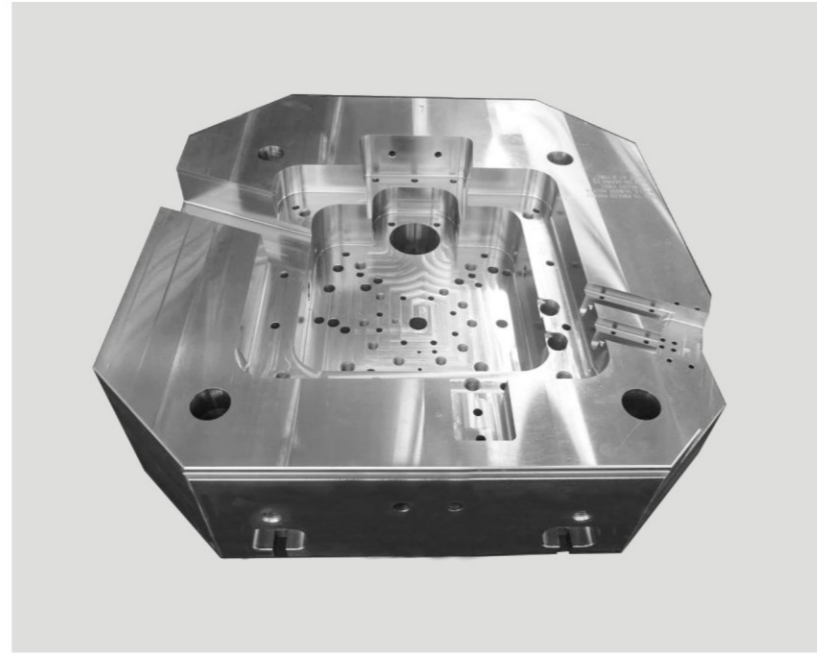

模架是模具不可分割的部分，可以说是整套模具的骨架。由于模架及模具所涉及的加工有很大差异，模架精度往往对模具的品质有决定性的影响。
The die frame is an integral part of the mould, which can be said to be the skeleton of the whole mould. Due to the large differences in the processing of mold and die, the precision of the mould has a decisive influence on the quality of the mould.

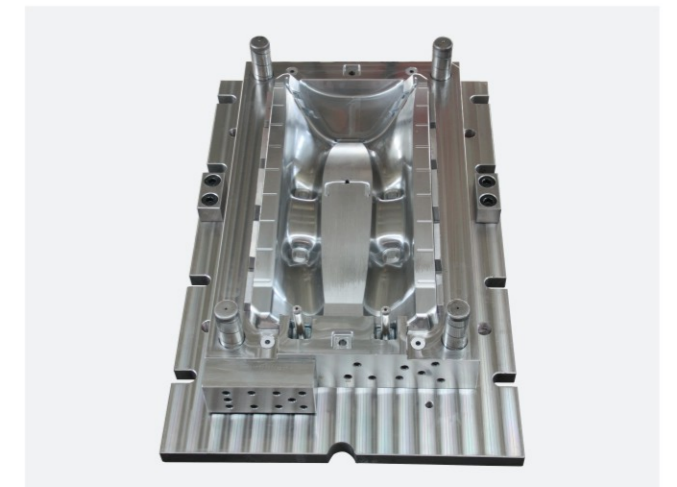
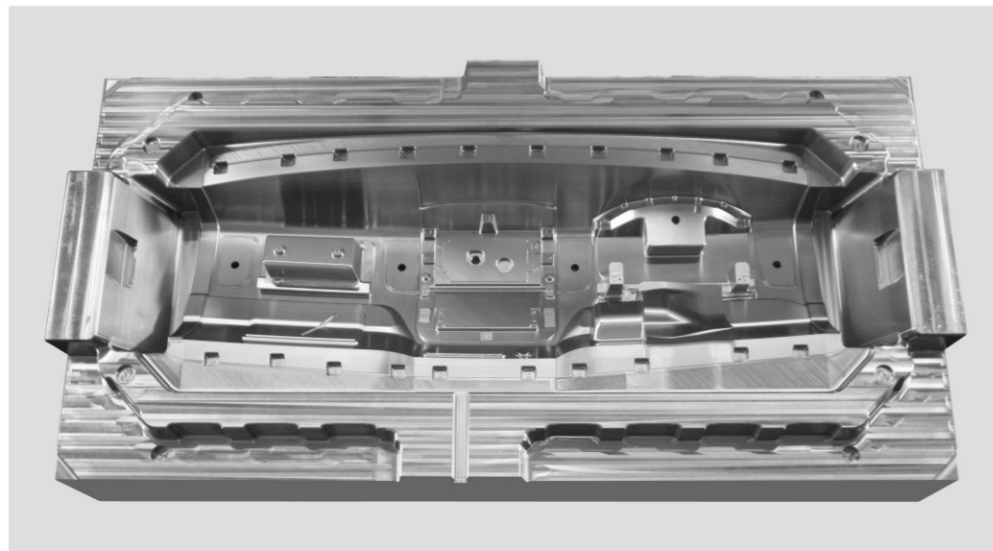
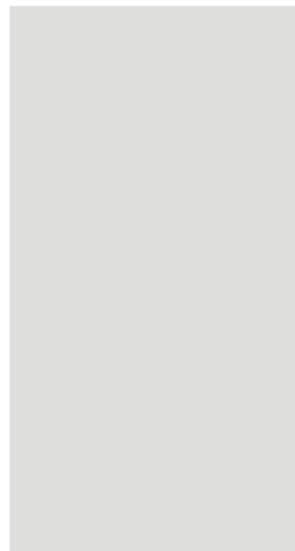
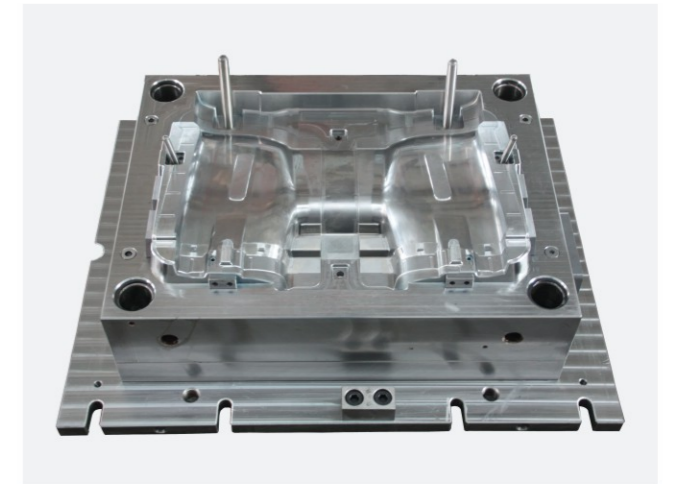
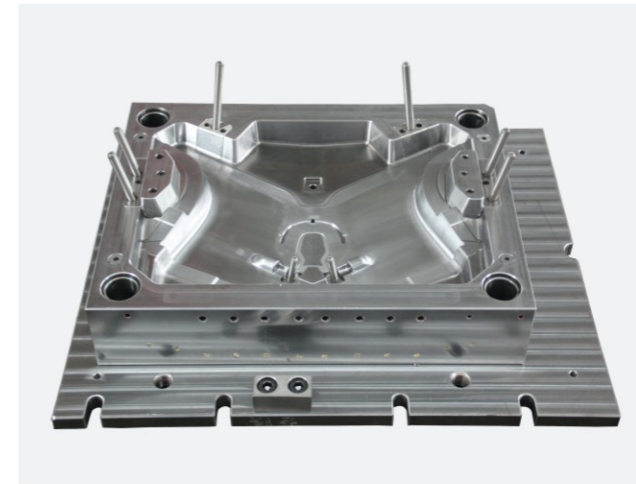
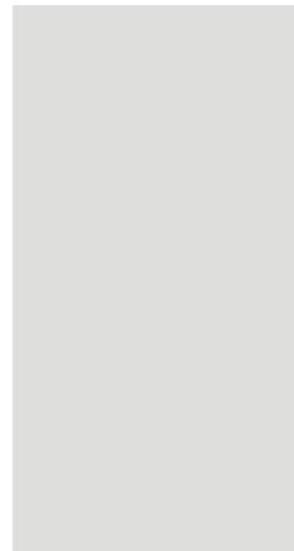
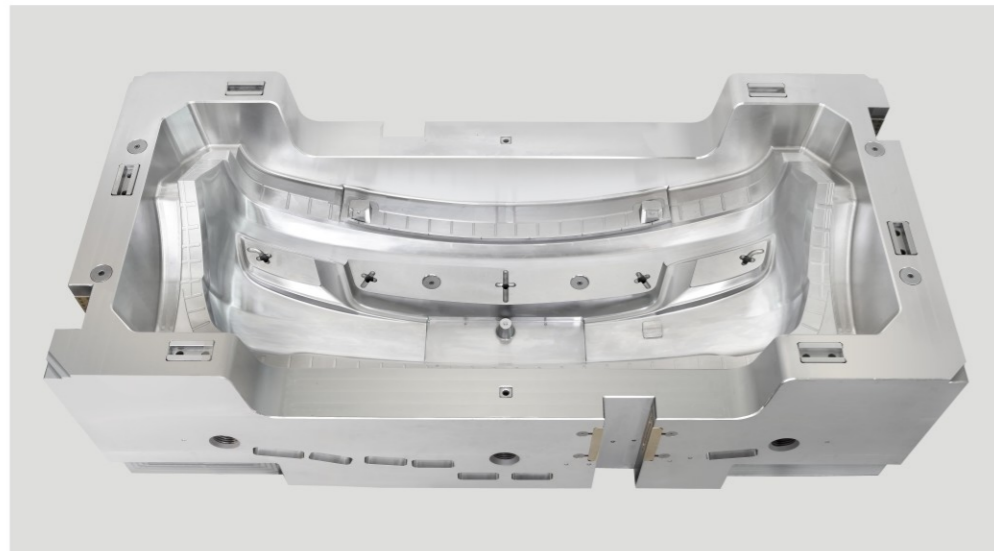
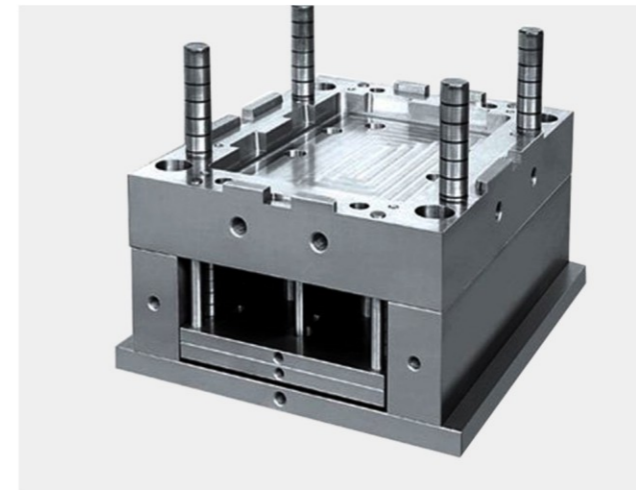

VSCUUM HEAT TREATMENT

真空热处理

公司拥有经验丰富的热处理高级工程师及团队，配置先进的真空热处理设备，多台双室真空淬火炉、预抽真空回火炉及超声波清洗机。严格执行工艺流程，确保热处理工件的产品质量。

The company has a rich experienced senior engineers and team for heat treatment, configured with advanced vacuum heat treatment equipments, many sets of double chamber vacuum quenching furnaces and for vacuum tempering furnaces and ultrasonic cleaning machines etc. Strictly carries out the process to ensure quality of heat treatment products.



高品质模具钢与先进的真空热处理相符合，得到的是模具的长寿命。
The combination of high quality die steel and vacuum heat treatment guarantees long life of the moulds.

CCT转变曲线 / Inversion curve

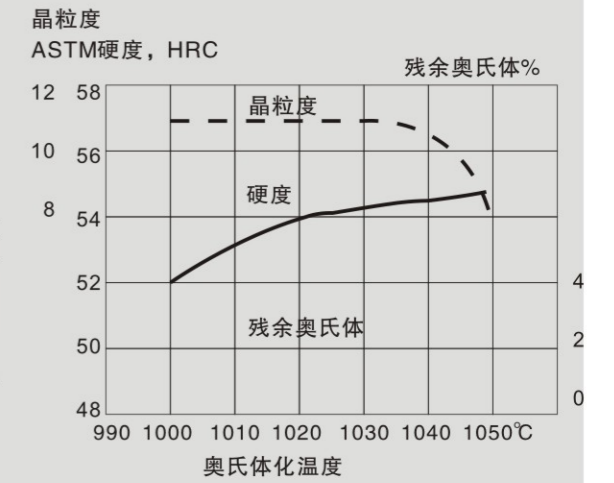
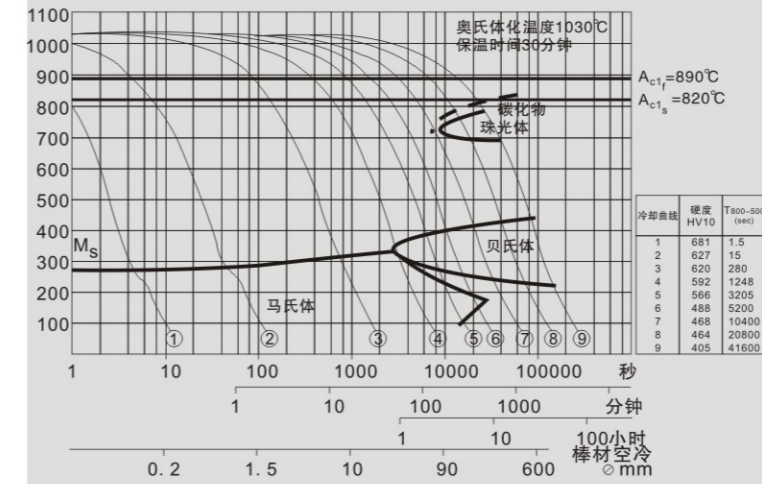

回火曲线 / Tempering curve

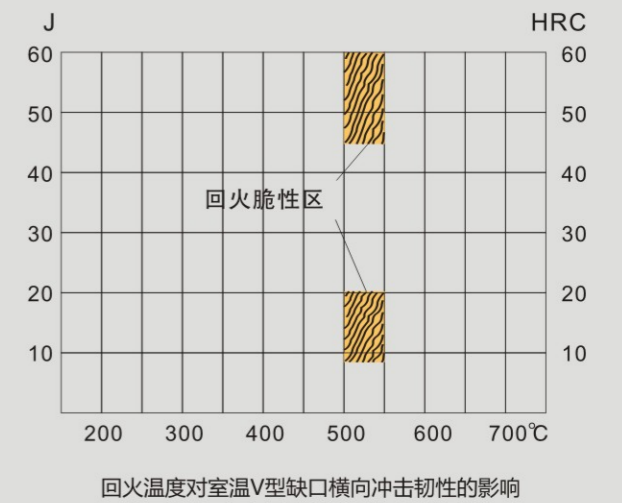
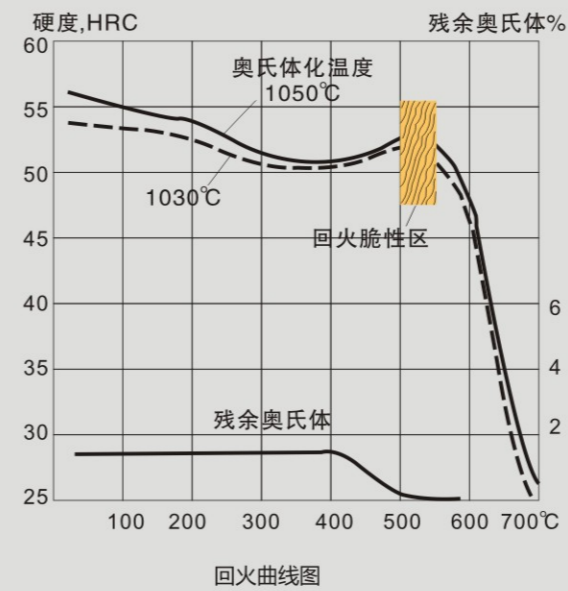

QUALITY ASSURANCE

品质保障

公司始终坚持“高质量产品，专业化服务”的质量方针，严格遵照ISO9001管理体系程序要求进行管理和控制，规范经营管理，在全员参与的基础上，切实提高产品质量。全面推行7S管理，各种高精度检测设备对进货材料的品质进行严格检测和控制，完备的代客订购、加工、运输体系，确保公司生产效率和产品质量。

We always uphold the quality principle of “high quality product, professional service”, strictly comply with ISO9001 in management and control to standardize operating management; and improve the quality of products on the basis of total involvement. We comprehensively carry out 7S supervision. Various of high precision checking devices strictly inspect and control the material quality; while complete ordering system, processing and transport system ensure us high production efficiency and good product quality.

▼ 三坐标测量仪



半自动显微硬度测量仪



超声波探伤仪



金相抛光机



金相切割机



金相镶嵌机



三目体视显微镜

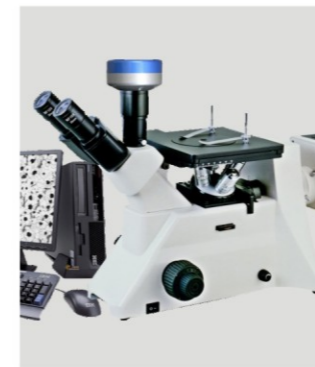

金相分析显微镜



手持式光谱仪



数显布氏硬度计